

MARCO[®]

MARINE TECH

Fischio Pneumatico Omologato

(Tromba per imbarcazioni da 12m a 20m)

Approved Pneumatic Whistle

(Marine horns for vessels between 12m to 20m in length)

150 004 12 - PW2-2BC 12V

150 004 13 - PW2-2BC 24V

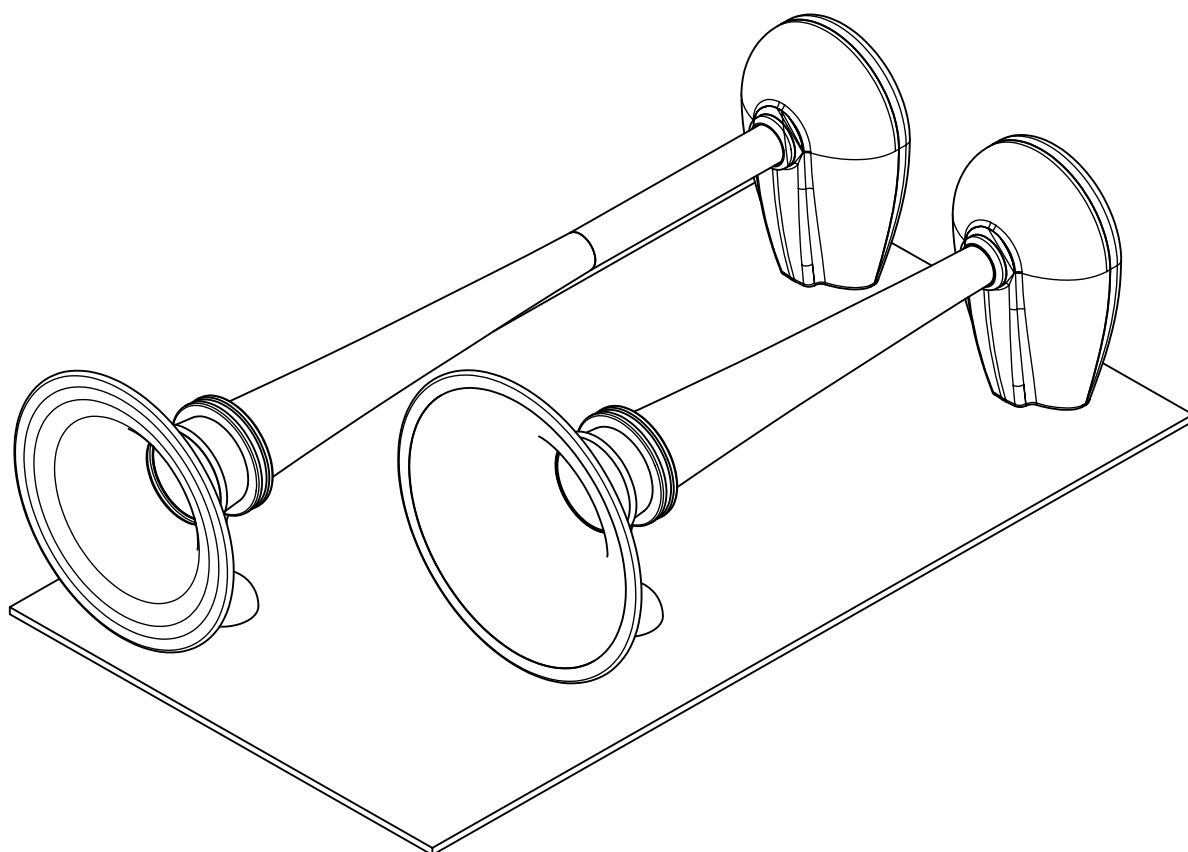

CE



Fischio Pneumatico Pneumatic Whistle

Tromba Nautica per imbarcazioni da 12m a 20m
Marine horns for vessels between 12m to 20m in length

Codice/Code

150 004 12 (12 V)

150 004 13 (24 V)

DESCRIZIONE DEL PRODOTTO / PRODUCT DESCRIPTION

Avvisatore sonoro omologato, completo di trombe cromate $\varnothing 200\text{mm}$ e $\varnothing 180\text{mm}$, valvola elettrica e accessori di montaggio. Omologazione RINA, LLOYD'S REGISTER MCA e BUREAU VERITAS in accordo alle norme internazionali COLREG 1972 IMO classe IV, NMMA ABYC A-23

Approved signalling whistle complete with chrome plated horn $\varnothing 200\text{mm}$ and $\varnothing 180\text{mm}$, electric valve and mounting accessories. Meets COLREG 1972 IMO class IV regulations.

Approvals: RINA, LLOYD'S REGISTER MCA and BUREAU VERITAS, NMMA ABYC A-23

DATI TECNICI / TECHNICAL DATA

TYPE	CODE	V	dB (1/3 OCT.)(1m)	Hz	DIMENSIONS (mm)	PCS PER CARTON
PW2-2BC	150 004 12	12	126	220 / 315	385 x 600 x 207	1
	150 004 13	24				

ISTRUZIONI PER L'INSTALLAZIONE DEL FISCHIO / INSTALLING INSTRUCTION OF THE WHISTLE

- Montare le trombe inclinandole leggermente verso il basso (5°) per evitare il ristagno d'acqua all'interno del cono;**
 - Collegare le trombe alla sorgente d'aria compressa attraverso il tubo Rilsan, utilizzando gli accessori del kit come da schema allegato;
 - Collegare i cavi elettrici alle elettrovalvole;
 - Collegare il pulsante di azionamento in serie al cavo rosso;
 - Collegare l'estremo del cavo rosso al polo positivo della batteria (+) e l'estremo del cavo nero al polo negativo della batteria (-).
- Install the horns angled slightly downward (5°) in order to avoid the water stagnation within the cone;**
 - Connect the horn to the air compressed source by the Rilsan pipe utilizing the accessories of the kit, see the layout attached;
 - Connect red and black cable to the electric valves;
 - Connect in series the service switch to the red cable;
 - Connect the extreme part of the red cable to the positive pole of the battery (+) and the extreme part of the black cable to the negative pole of the battery (-).

DATI TECNICI ELETTRICI / ELECTRICAL TECHNICAL DATA

Sezioni cavi del pulsante di azionamento: 1,5 mm² fino a 20 m.

Cables section of service switch: 1,5 mm² for connections up to 20 m.

RISOLUZIONE DI PROBLEMI / PROBLEM RESOLUTIONS

Nel caso di mancato funzionamento del sistema procedere come segue :

Piccoli corpi solidi possono arrivare alle membrane bloccandone il funzionamento. In tal caso bisogna smontare la tromba, pulire le membrane, e rimontare il tutto.

In the case of a system malfunction proceed as follows :

Impurities can reach the membrane blocking the normal performance of the whistle. In this case dismantle the horn, clean the membranes and re-assemble.

SCHEMA DI COLLEGAMENTO / CONNECTION LAYOUT

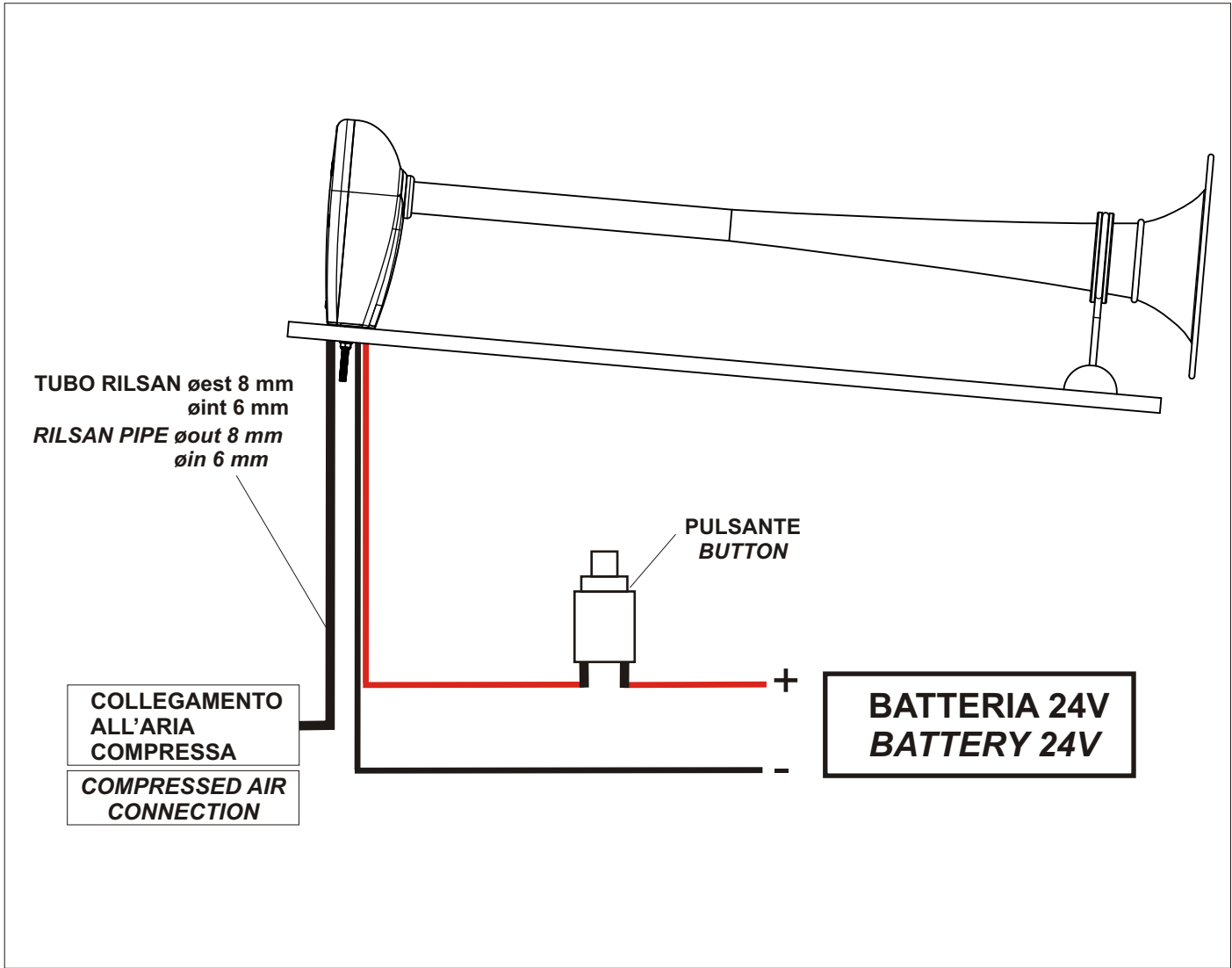

TAPPETO IN GOMMA / RUBBER CARPET

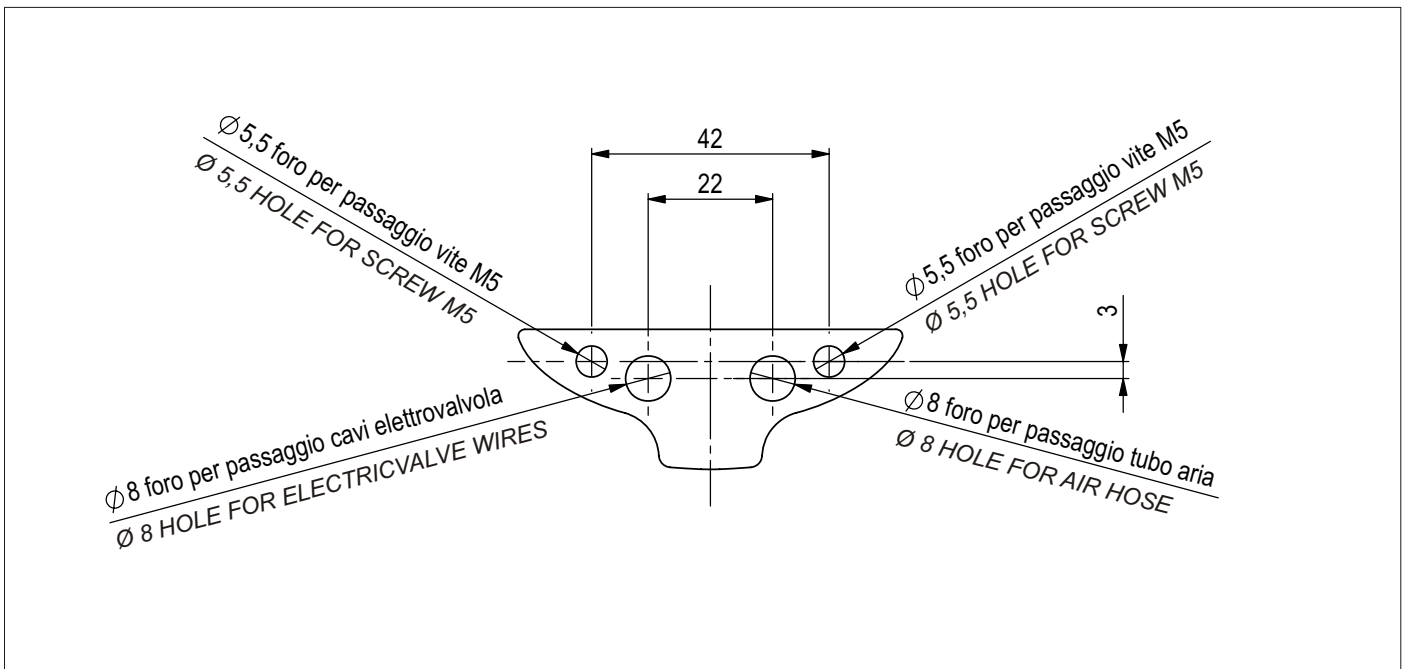

ESPLOSO / EXPLODED VIEW

Pos.	Q.tà	Descrizione
1	1	CORNETTO
2	1	O-RING
3	1	GUSCIO FRONTALE BLITZ
4	1	GHIERA
5	2	GRANO
6	1	O-RING
7	1	BASE INFERIORE BLITZ
8	1	MEMBRANA
9	1	BASE SUPERIORE BLITZ
10	6	VITE
11	1	DISCO
12	1	O-RING
13	1	NIPPLO
14	1	FORCELLA BLITZ
15	3	MOLLA
16	1	O-RING
17	3	VITE M5X25
18	1	VITE M5X30
19	1	TAPPETO BLITZ
20	1	GUSCIO POSTERIORE BLITZ
21	2	RONDELLA
22	2	VITE
23	2	RONDELLA
24	2	DADO
25	1	ANELLO
26	1	COPERCHIO
27	1	GANCIO
28	1	GRANO
29	1	SOSTEGNO
30	1	O-RING
31	1	O-RING
32	2	VITE
33	1	ELETTROVALVOLA
34	1	DADO

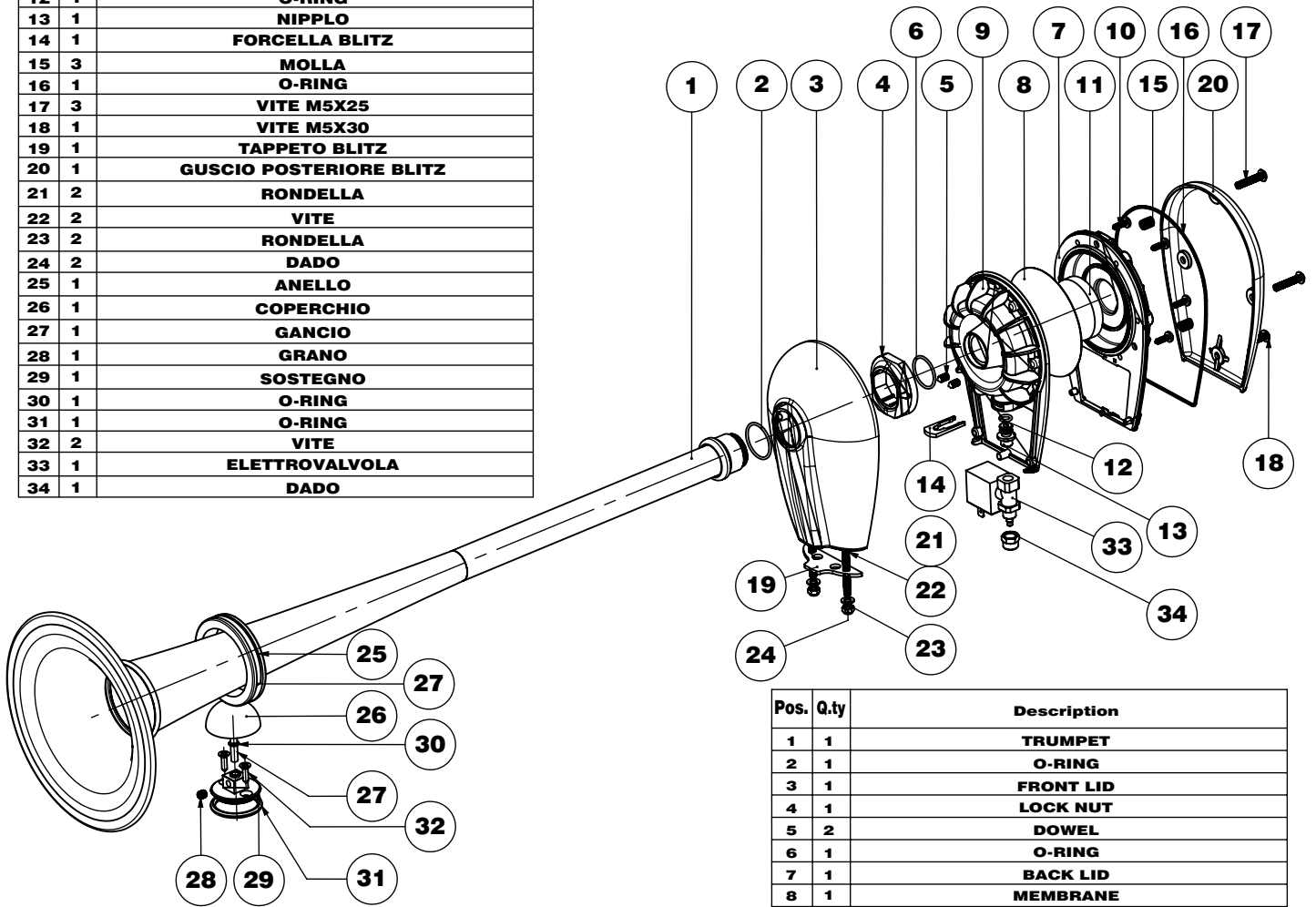

Pos.	Q.ty	Description
1	1	TRUMPET
2	1	O-RING
3	1	FRONT LID
4	1	LOCK NUT
5	2	DOWEL
6	1	O-RING
7	1	BACK LID
8	1	MEMBRANE
9	1	FRONT LID
10	6	SCREW
11	1	DISC
12	1	O-RING
13	1	NIPPLE
14	1	FORK BLITZ
15	3	SPRING
16	1	O-RING
17	3	SCREW M5X25
18	1	SCREW M5X30
19	1	CARPET
20	1	BACK LID
21	2	WASHER
22	2	SCREW
23	2	WASHER
24	2	NUT
25	1	RING
26	1	COVER HOOK
27	1	INOX HOOK
28	1	SECURITY DOWEL
29	1	SUPPORT HOOK
30	1	O-RING
31	1	O-RING
32	2	SCREW
33	1	ELECTRIC VALVE
34	1	NUT

SEQUENZA DI MONTAGGIO / WHISTLE MOUNTING SEQUENCE

1. Forare il piano di appoggio (14) della tromba utilizzando il tappeto in gomma (11) come dima;
2. Svitare le tre viti M5x25 (1) e la vite M5x30 (2);
3. Togliere il guscio posteriore (3);
4. Estrarre le tre molle (5);
5. Sfilare delicatamente la cartuccia (6) infilando un cacciavite tra il guscio che la contiene (8) e la cartuccia stessa, facendo leva nel punto "C" (Tab.1);
6. Appoggiare il tappeto in gomma (11) sul piano di appoggio (14);
7. Appoggiare il guscio anteriore (8) sul tappeto in gomma (11);
8. Fissare il guscio anteriore completo di tromba (8) sul piano di appoggio (14) con le viti M5 (9) complete di rondelle elastiche (10) e bloccarlo tramite i dadi autobloccanti (13) preceduti dalle rondelle (12);
9. Infilare dal basso il tubo rilsan nell' apposito foro (A) e nel dado (15), calzarlo sulla elettrovalvola (16) e serrarlo con il dado (15);
10. Infilare i cavi elettrici nell' apposito foro (B);
11. Centrare la cartuccia (6) sul tubo centrale del guscio anteriore (8). Accertarsi che il tubo monti l'OR (7) in testa, che la cartuccia (6) monti l'OR (4) sul suo perimetro e che abbia le tre molle di compensazione (5) nelle apposite sedi;
12. Appoggiare il guscio posteriore (3) alla cartuccia (6) appena inserita;
13. Fissare le viti M5x25 (1), M5x30 (2) e portare in appoggio il guscio posteriore (3) al guscio anteriore completo di tromba (8). Verificare che in chiusura l'OR (4) perimetrale alla cartuccia (6) non fuoriesca dal guscio (3) garantendo così la tenuta.

1. *Drill the supporting surface of the horn (14) using the rubber mat (11) as template;*
2. *Unscrew the M5X25 (1) and M5x30 (2) screws ;*
3. *Remove the back cover (3);*
4. *Remove the spring (5);*
5. *Slip off carefully the cartridge (6) with a screwdriver at the point "C" (Tab.1);*
6. *Put the rubber mat (11) just next to the fixing holes previously made;*
7. *Put the horn housing complete with trumpet (8) on the rubber mat (11);*
8. *Fix the horn housing complete with trumpet (8) on the supporting surface (14) by two M5 screws (9) and elastic washers (10) and lock it through the self-locking nut (13) and washers (12);*
9. *Insert from below the rilsan tubing into the specially provided hole (A) and insert into the nut (15);*
10. *Insert the electric cable into the specially provided hole (B);*
11. *Insert carefully the cartridge (6) into the horn housing complete with trumpet (8) centring it on the trumpet tube end. Make sure that the trumpet tube is complete with the O-ring (7) and that the cartridge (6) has the O-ring (4) on the outer edge and that the three compensation springs (5) are located in the specially provided seats.*
12. *Place the back cover (3) on the inserted cartridge (6).*
13. *Insert the M5x25 (1), and M5x30 (2) screws into the specially provided seats and screw them until the back cover (3) rests on the horn housing complete with trumpet (8). Make sure that the O-ring (4) of the outer edge of the cartridge (6) does not protrude from the back cover (3) ensuring therefore a perfect tightness.*

SOSTITUZIONE ELETTROVALVOLA / ELECTRIC VALVE SUBSTITUTION

Tab.2

1. Svitare il dado sul tubo Rilsan;
2. Sfilare la forcella;
3. Estrarre l'elettrovalvola.

1. *Unscrew the Rilsan tube nut;*
2. *Extract the fork;*
3. *Extract the electric valve.*

SCHEMA DI MONTAGGIO / MOUNTING LAYOUT

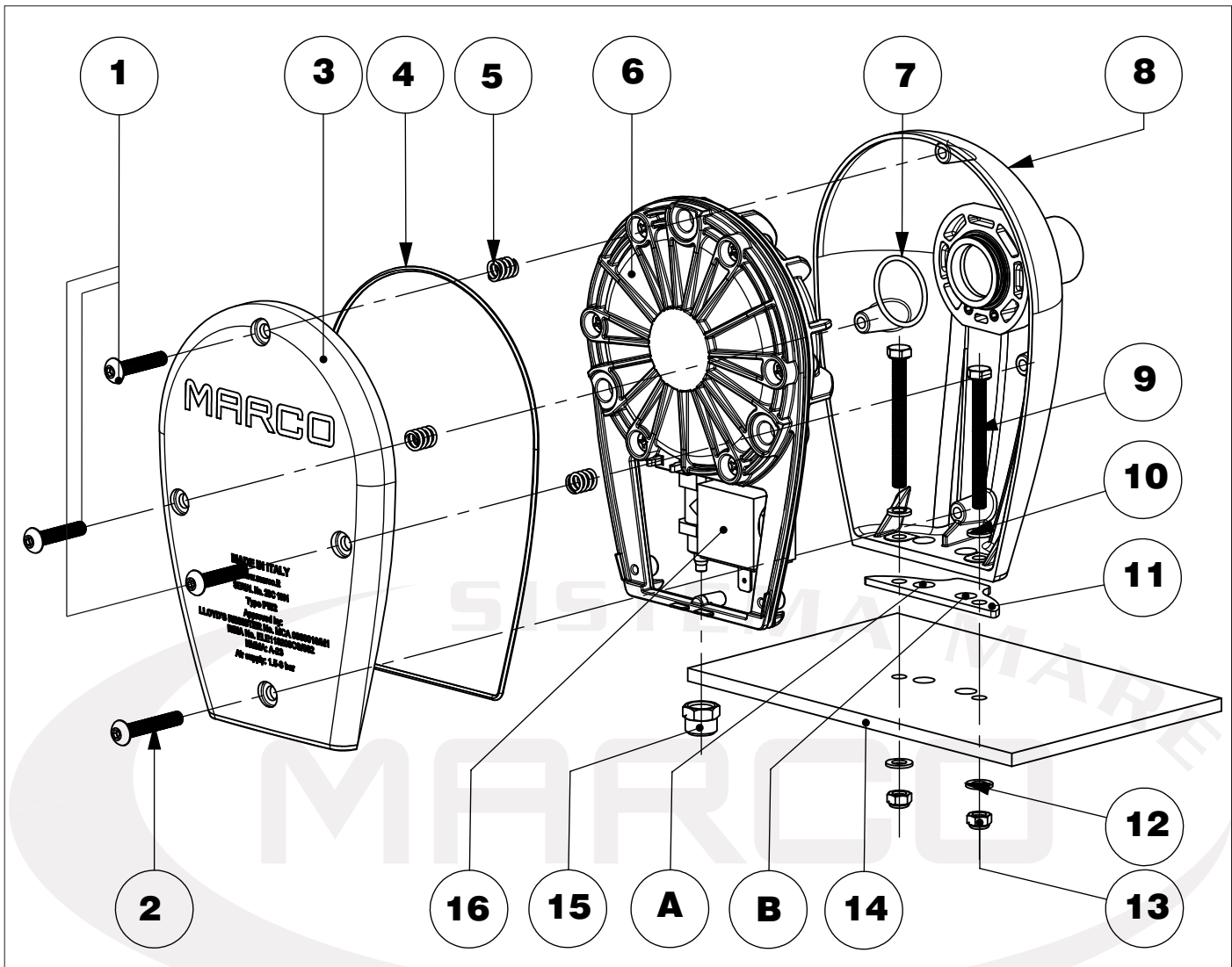

Tab.1

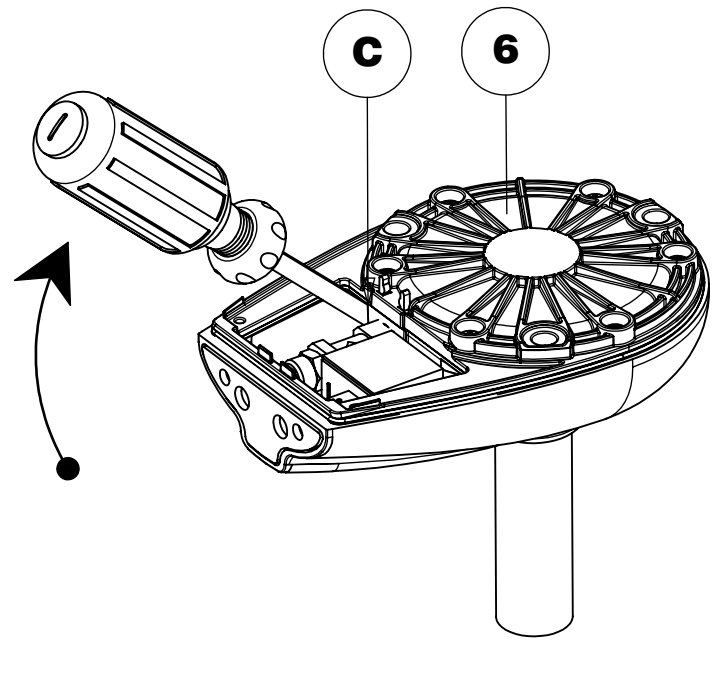

Tab.2

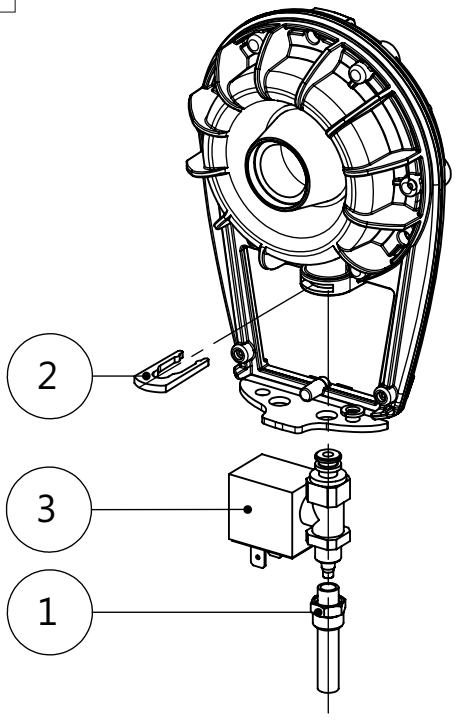

DIMENSIONI DI MASSIMA / DIMENSIONS

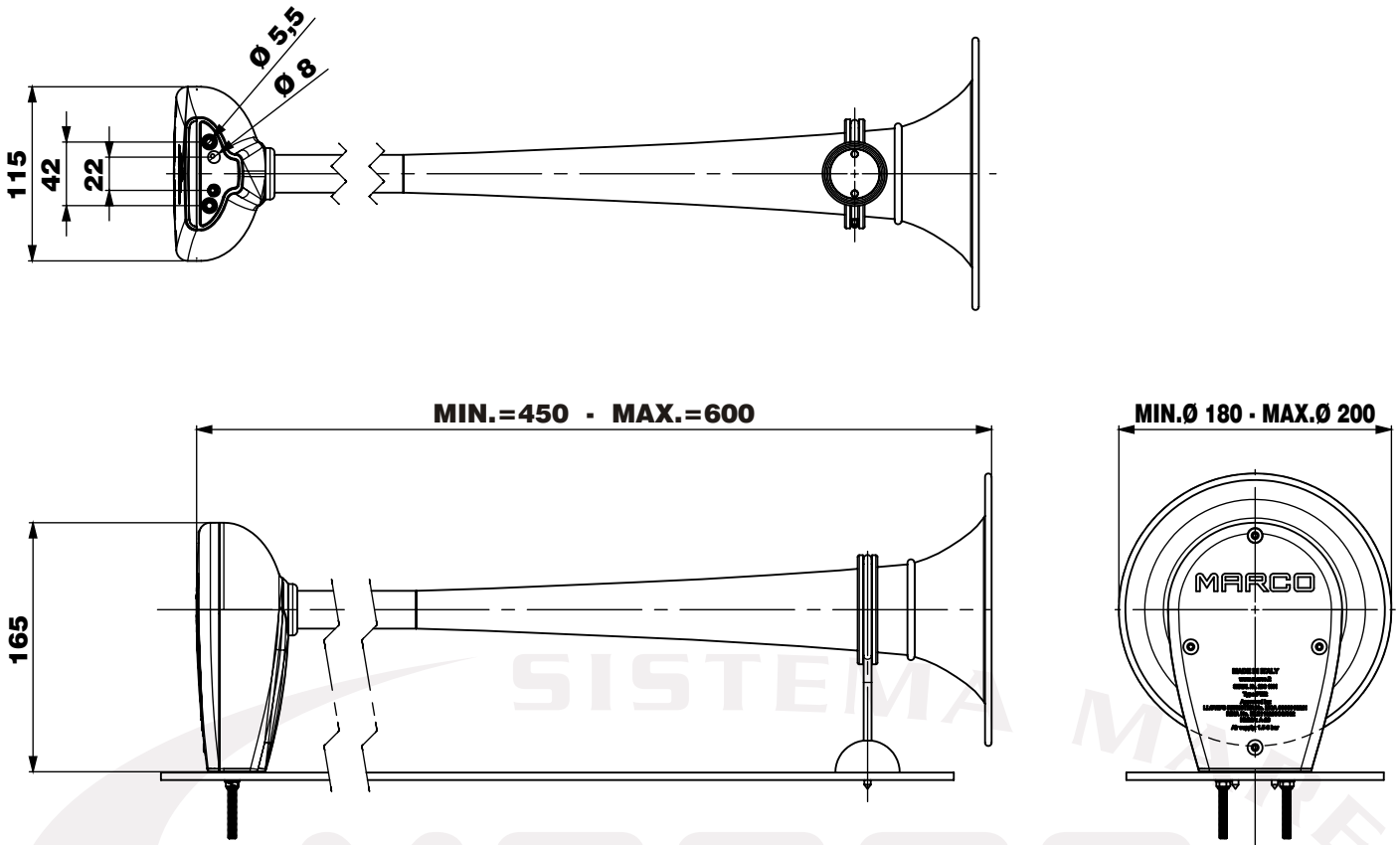

GARANZIA / WARRANTY

1. Il periodo di garanzia è di 2 anni dalla data d'acquisto come risulta dalla relativa fattura.
2. Nel caso la fattura non fosse disponibile il periodo di garanzia di 2 anni, sarà calcolato dalla data di fabbricazione.
3. La garanzia decade e s'intende nulla in caso d'utilizzazione non corretta o nel caso venissero ignorate le istruzioni contenute nel presente manuale.
4. La garanzia copre solamente i difetti di fabbricazione.
5. La garanzia non copre i costi connessi di installazione e smontaggio.
6. I costi di trasporto sono rimborsabili solo nel caso in cui la garanzia è stata debitamente riconosciuta e accettata da Marco S.p.A. Questi costi saranno limitati ai costi di spedizione tra il magazzino di Marco S.p.A. e la sede del cliente.
7. Nessuna nota di credito o reso sarà emessa prima di un test eseguito dal controllo di qualità di Marco S.p.A. che dichiari difettoso il prodotto.

1. *The Warranty period is 2 years from date of purchase on production of the appropriate sales invoice.*
2. *Should the original sales invoice not be available, then the 2 year warranty period will be valid from date of production.*
3. *The Warranty becomes null and void in the case of incorrect utilization or disregard of the instructions contained herein.*
4. *The Warranty only covers original production defects.*
5. *The Warranty does not cover any related installation costs involved.*
6. *Transport costs are refundable only in the case where warranty has been duly recognized and accepted by Marco Spa. These costs will be limited to the actual shipment costs between Marco Spa warehouse and the client's delivery address.*
7. *No credit notes or replacement items will be issued prior to the receipt and proper testing of any Marco goods that are deemed faulty.*



TYPE APPROVAL CERTIFICATE



N. ELE252018CS001

This is to certify that the product below is found to be in compliance with the applicable requirements of the RINA type approval system.

<i>Description</i>	Ship's Whistle
<i>Types</i>	PW2 and PW3
<i>Applicant</i>	Marco S.p.A. Via Mameli, 10 25014 Castenedolo (BS) ITALY
<i>Manufacturer</i>	Marco S.p.A. Via Mameli, 10 25014 Castenedolo (BS) ITALY
<i>Testing Standards</i>	Convention on the International Regulations for preventing collisions at sea, 1972 _ COLREG (Ref. to Italian Law n. 1085 _27th December 1977)

Issued in Genova on August 28, 2018

This certificate is valid until August 28, 2023

RINA Services S.p.A.

Valerio Bonanni





TYPE APPROVAL CERTIFICATE



N. ELE252018CS001

Whistle type PW2**Field of application (acc. to COLREG Regulations)**

Vessels having length $L < 20$ meters
Sound pressure level 1/3 octave band @ 1 m : 120 dB
Audibility: 0,5 mile

Feeder

Compressed air.
Air pressure supply : from 0,15 to 0,30 MPa.

Reference documents:

RINA Report n. 2013/CS/01/534 (19/07/2013): frequency and sound pressure measurements (19/07/2013)
MARCO Letter on 06/02/2008.
Drawing no. 5.412/ S stamped by RINA on 03/06/1988

Whistle type PW3**Field of application (acc. to COLREG Regulations)**

Vessels having length $20 \leq L < 75$ meters
Sound pressure level 1/3 octave band @ 1 m : 130 dB
Audibility: 1 mile

Feeder

Compressed air.
Air pressure supply : from 0,60 to 1,20 MPa.

Reference documents:

RINA Report n. 2013/CS/01/534 (19/07/2013): frequency and sound pressure measurements (19/07/2013)
MARCO Letter on 06/02/2008.
Drawing no. 5.413 stamped by RINA on 13/04/1988.



Notified Body authorised by the MCA

CERTIFICATE OF TYPE APPROVAL

This is to certify that

LLOYD'S REGISTER, specified as a "person" under the terms of The Merchant Shipping (Delegation of Equipment Approval) Regulations 1996, did undertake the relevant type approval procedures of the equipment identified below which was found to be in compliance with the essential COLREG 72 requirements subject to any conditions in the Design Appraisal Document hereto.

Producer	Marco SpA
Address	Via Mameli 10 25014 Castenedolo Brescia Italy
Equipment Description	SHIPS SOUND SIGNAL (WHISTLE) AIR OPERATED
Type	PW2
Specified Standard	International Regulations for Preventing Collisions at Sea 1972, Consolidated Edition 2002, Annex III, 1(a) to (d) inclusive. EN 60945 (2002)

The attached Design Appraisal Document forms part of this certificate.

This certificate remains valid up to the expiry dated unless cancelled or revoked, or until such date where it is superseded by the requirements of the Marine Equipment Directive whichever is the earlier, provided the conditions in the attached schedule are complied with and the equipment remains satisfactory in service.

Date of issue	11 March 2016	Expiry date	10 March 2021
Certificate No.	MCA 1600003	Signed	
Sheet No	1 of 3	Name	L. Thomas Surveyor to Lloyd's Register EMEA A Member of the Lloyd's Register Group

Note:

This certificate is not valid for equipment, the design or manufacture of which has been varied or modified from the specimen tested. The manufacturer should notify the nominated body named on this certificate of any modification or changes to the equipment in order to obtain a valid Certificate.



This certificate is issued under the authority given in Merchant Shipping Notice No MSN 1735 (M+F) as amended to date.

Lloyd's Register Group Limited, its affiliates and subsidiaries and their respective officers, employees or agents are, individually and collectively, referred to in this clause as the 'Lloyd's Register'. Lloyd's Register assumes no responsibility and shall not be liable to any person for any loss, damage or expense caused by reliance on the information or advice in this document or howsoever provided, unless that person has signed a contract with the relevant Lloyd's Register entity for the provision of this information or advice and in that case any responsibility or liability is exclusively on the terms and conditions set out in that contract.

This is a copy of an electronic document. In the event of any conflict or ambiguity between the copy and the electronic document, which is retained and published by Lloyd's Register, the original electronic and certified version shall always prevail.



Lloyd's
Register

Lloyd's Register EMEA

London Design Support Office
71 Fenchurch Street, London, EC3M 4BS
Telephone 020 7423 2416 Fax 020 7423 2053
Email med@lr.org

Page	2 of 3
Document number	MCA 1600003
Issue number	1

DESIGN APPRAISAL DOCUMENT

Date	11 March 2016	Quote this reference on all future communications	MTES/SFS/TA/LT/WP24449231
------	---------------	---	---------------------------

ATTACHMENT TO CERTIFICATE OF TYPE APPROVAL No. MCA 1600003

The undernoted documents have been appraised for compliance with the relevant International Conventions and UK legislation for the Type Approval of Marine Equipment for use on Merchant Ships Registered in the United Kingdom.

This Design Appraisal Document forms part of the Certificate that is issued under the authority given in the MCA Merchant Shipping Notice No MSN 1735.

EXAMINED DOCUMENTS

LR Brescia email	11.03.2008
Marco letter	10.03.2008
PW2 Data Sheet, Rev 07 (Trumpet)	22.07.2014

TEST REPORTS

IQNet Certificate No. CH-21294	07.02.2006
SQS Certificate No. 21294	07.02.2006
Environmental and Vibration Test, Test Report No: AERO15_016 , Rev 0	15.09.2015
Sound Pressure Test after Environmental and Vibration test, Rev 0	18.12.2015

CONDITIONS OF CERTIFICATION

1. The PW2 whistles may only be fitted to vessels greater than 12 meters but less than 20 metres in length
2. The onboard arrangements and installation of this whistle is not part of this certificate, all such arrangements are to be to the satisfaction of the attending surveyor
3. Each whistle is to be delivered with a copy of this certificate
4. Instructions for use and maintenance are to be supplied with each whistle
5. If the specified standards are amended during the validity of this certificate, this product type is to be re-approved prior to it being supplied to vessels to which the amended standards apply
6. Production items are to be manufactured in accordance with a quality control system which shall be maintained to ensure compliance with SOLAS Regulation III/5
7. Production tests are to be conducted in accordance with the applicable requirements of IMO Resolution MSC.81 (70), Part 2 and each item, batch, or lot be delivered with an LR Certificate of SOLAS Production Testing issued by the attending LR Surveyors following their witness of the tests. This does not preclude any further testing to additional requirements of the Marine Administration of the country where the ship is registered (i.e. the flag state) or those acting on behalf of that Administration
8. Should a change of Place of Production from that stated below be required i.e. where the stages of manufacture/assembly/testing of this product take place, the new Place of Production is to be advised to us prior to the change taking place. This Certificate will require to be updated for Approval to be maintained

Lloyd's Register Group Limited, its affiliates and subsidiaries and their respective officers, employees or agents are, individually and collectively, referred to in this clause as the 'Lloyd's Register'. Lloyd's Register assumes no responsibility and shall not be liable to any person for any loss, damage or expense caused by reliance on the information or advice in this document or howsoever provided, unless that person has signed a contract with the relevant Lloyd's Register entity for the provision of this information or advice and in that case any responsibility or liability is exclusively on the terms and conditions set out in that contract.



Lloyd's Register

Lloyd's Register EMEA

London Design Support Office
 71 Fenchurch Street, London, EC3M 4BS
 Telephone 020 7423 2416 Fax 020 7423 2053
 Email med@lr.org

Page	3 of 3
Document number	MCA 1600003
Issue number	1

DESIGN APPRAISAL DOCUMENT

Date	11 March 2016	Quote this reference on all future communications	MTES/SFS/TA/LT/WP24449231
------	---------------	---	---------------------------

ATTACHMENT TO CERTIFICATE OF TYPE APPROVAL No. MCA 1600003

PLACE OF PRODUCTION

Marco SpA
 Via Mameli 10
 25014 Castenedolo
 Brescia
 Italy



Lijo Thomas
 Senior Specialist
 Statutory Fire & Safety
 Marine Technology and Engineering Services
 Lloyd's Register EMEA

Lloyd's Register Group Limited, its affiliates and subsidiaries and their respective officers, employees or agents are, individually and collectively, referred to in this clause as the 'Lloyd's Register'. Lloyd's Register assumes no responsibility and shall not be liable to any person for any loss, damage or expense caused by reliance on the information or advice in this document or howsoever provided, unless that person has signed a contract with the relevant Lloyd's Register entity for the provision of this information or advice and in that case any responsibility or liability is exclusively on the terms and conditions set out in that contract.

**BUREAU
VERITAS****Marine & Offshore
Division****Certificate number:** 14450/C1 BV**File number:** NAV 39/1469/02**Product code:** 4005H*This certificate is not valid when presented without the full attached schedule composed of 7 sections*

www.veristar.com

TYPE APPROVAL CERTIFICATE

*This certificate is issued to***MARCO SpA**

Castenedolo (BS) - ITALY

*for the type of product***SHIP's SOUND SIGNALS (WHISTLES)**

Air whistle type: PW2/PW3

Requirements:

Bureau Veritas Rules for the Classification of Steel Ships.

This certificate is issued to attest that BUREAU VERITAS did undertake the relevant approval procedures for the product identified above which was found to comply with the relevant requirements mentioned above.

This certificate will expire on: 02 Sep 2020**For BUREAU VERITAS,**

At BV GENOA, on 21 May 2015,

Carlo Bozzetti



This certificate remains valid until the date stated above, unless cancelled or revoked, provided the conditions indicated in the subsequent page(s) are complied with and the product remains satisfactory in service. This certificate will not be valid if the applicant makes any changes or modifications to the approved product, which have not been notified to, and agreed in writing with BUREAU VERITAS. Should the specified regulations or standards be amended during the validity of this certificate, the product(s) is/are to be re-approved prior to it/they being placed on board vessels to which the amended regulations or standards apply. This certificate is issued within the scope of the General Conditions of BUREAU VERITAS Marine & Offshore Division available on the internet site www.veristar.com. Any Person not a party to the contract pursuant to which this document is delivered may not assert a claim against BUREAU VERITAS for any liability arising out of errors or omissions which may be contained in said document, or for errors of judgement, fault or negligence committed by personnel of the Society or of its Agents in establishment or issuance of this document, and in connection with any activities for which it may provide.

The electronic version is available at: <http://www.veristarm.com/veristamb/jsp/viewPublicPdfTypec.jsp?id=mjoghqcrjm>

BV Mod. Ad.E 530 October 2014

This certificate consists of 2 page(s)

THE SCHEDULE OF APPROVAL

1. PRODUCT DESCRIPTION:

Types	Frequency	Sound pressure level (1m)	Length of vessels
Air whistle type PW2	630 Hz	123dB	< 20 m
Air whistle type PW3	630 Hz	132dB	20 ≤ L < 75 mm

2. DOCUMENTS AND DRAWINGS:

According to Manufacturer's specifications filed in NAV 39/1469/02.

3. TEST REPORTS:

3.1 - Air whistle type PW2:

Department of Trade Marine Directorate Certificate of Inspection and Tests,
EMIT Vibration test report RP 712 FIA 86,
City University London report on measurement sound output.

3.2 - Air whistle type PW3:

Department of Trade Marine Directorate Certificate of Inspection and Tests,
City University London report on measurement sound output.

4. APPLICATION / LIMITATION:

4.1 - Air whistle type PW2 to be installed on vessels < 20 m in length,
Air whistle type PW3 to be installed on vessels 20 ≤ L < 75 m in length.

4.2 - On board installation & Maintenance requirements according to the specified regulations and standard stated on the front page of the certificate.

5. PRODUCTION SURVEY REQUIREMENTS:

5.1 - The above products are to be supplied by **MARCO SpA** in compliance with the type described in this certificate.

5.2 - This type of product is within the category HBV of Bureau Veritas Rule Note NR320.

5.3 - **MARCO SpA** has to make the necessary arrangements to have its works recognised by Bureau Veritas in compliance with the requirements of NR320 for HBV products :

MARCO SpA
Via Mameli 10,
25014 Castenedolo Brescia
ITALY

6. MARKING OF PRODUCT:

6.1 - Maker's name or trademark,

6.2 - Serial number of the units,

6.3 - Equipment type number or model identification under which it was type-tested.

7. OTHERS:

7.1 - This approval is given on the understanding that the Society reserves the right to require check tests to be carried out on the Whistles at any time and that **MARCO SpA, 25014 Castenedolo (BS) - Italia**, will accept full responsibility for informing shipbuilders, shipowners or their sub-contractors of the proper methods of use and general maintenance of the units and the conditions of this approval.

7.2 - This Certificate supersedes the Type Approval Certificate No.14450/C1 BV issued on 07 May 2015 by the Society.

*** END OF CERTIFICATE ***

BSH
Az.: 4615/6023034/16

Marco
Via Mameli 10
25014 CASTENEDOLO Brescia
Italien

Ihr Antrag auf Baumusterprüfung von Navigationsausrüstung vom 12.04.2016
Your application for type examination of navigation equipment dated 12.04.2016



BUNDESAMT FÜR
SEESCHIFFFAHRT
UND
HYDROGRAPHIE

Hamburg,
19.04.2016

Bescheid über die Anerkennung der nationalen Zulassung eines EU-Mitgliedstaates

Notification of acceptance of a national type approval of a EU member state

Sehr geehrte Damen und Herren,
Dear Madam and Sir,

für die Navigations Ausrüstung mit der Bezeichnung **PW2, PW3**
For the navigation equipment with the type designation PW2, PW3

wird die mit anliegendem Zertifikat Nr. **MCA1600002, MCA1600003**
the approval granted with attached certificate no. MCA1600002, MCA1600003

für MCA(UK) ausgesprochene Zulassung vom Bundesamt für Seeschifffahrt und Hydrographie (BSH) für die Anwendung auf Schiffen unter Deutscher Flagge akzeptiert.
Will be accepted by the Federal Maritime and Hydrographic Agency (BSH) for the use on german flag vessels.

Bedingungen

Conditions

Diese Anerkennung erlischt bei Fristablauf, Rücknahme oder Widerruf. Der Widerruf kann ausgesprochen werden, wenn die serienmäßig gefertigten nautischen Ausrüstungsgegenstände nicht mit dem zugelassenen Baumuster übereinstimmen.

This acceptance expires after lapse of time, withdrawal or revocation. A revocation may be ordered if navigational equipment manufactured in serial production is not in compliance with the type-tested prototype.

Auflagen

Obligations

Der Hersteller oder sein bevollmächtigter Vertreter hat sicherzustellen, dass alle auf Grund dieses Bescheids gefertigten nautischen Ausrüstungsgegenstände mit den geprüften Unterlagen und mit dem Baumuster übereinstimmen.

The manufacturer or his authorized representative has to ensure that navigational equipment manufactured on the basis of this acceptance, is in compliance with the approved documentation and the type-approved prototype.

Jeder serienmäßig auf Grund dieses Bescheids gefertigte Bestandteil des nautischen Ausrüstungsgegenstandes muss an gut sichtbarer Stelle und in dauerhafter Form mit der Gerätebeschriftung entsprechend der europäischen Norm EN 60945 gekennzeichnet sein und darf mit der Baumusternummer (Nummer der Baumusterprüfbescheinigung) versehen werden. Ausgenommen davon sind Bauteile, die in der unter Wasser liegenden Außenhaut des Schiffes eingebaut werden.

Every navigational equipment component which is produced in series on the basis of this acceptance must be marked permanently and visibly with the equipment identification according to the european standard EN 60945 type and may be marked with the approval number (number of the type approval certificate). This does not apply to components installed in the vessel's outside plating below the waterline.

Der Hersteller oder sein bevollmächtigter Vertreter hat den vom Bundesamt für Seeschifffahrt und Hydrographie betrauten Personen zu gestatten, durch stichprobenartige Nachprüfungen festzustellen, ob serienmäßig hergestellte Ausrüstungsgegenstände dem geprüften Baumuster entsprechen. Das Bundesamt für Seeschifffahrt und Hydrographie kann zu diesem Zweck beim Hersteller oder seinem bevollmächtigten Vertreter Proben anfordern oder entnehmen.

The manufacturer or his authorized representative has to allow to persons authorized by the Federal Maritime and Hydrographic Agency to take random samples to prove whether equipment manufactured in serial production is in compliance with the type-approved prototype. Therefore, the Federal Maritime and Hydrographic Agency may take or demand samples from the manufacturer or his authorized representative.

Es wird empfohlen, jedem ausgelieferten Ausrüstungsgegenstand eine vollständige Kopie der Anerkennung beizufügen.

It is recommended that a complete copy of the admission certificate is provided with each equipment delivery.

Hinweise

remarks

Das Bundesamt für Seeschifffahrt und Hydrographie behält sich vor, weitere Auflagen zu erteilen.

The Federal Maritime and Hydrographic Agency reserves the right to impose additional obligations.

Rechtsbehelfsbelehrung

Notice on legal remedies available

Gegen diesen Bescheid kann innerhalb eines Monats nach Bekanntgabe Widerspruch erhoben werden. Der Widerspruch ist beim Bundesamt für Seeschifffahrt und Hydrographie, Bernhard-Nocht-Str. 78, 20359 Hamburg, schriftlich oder zur Niederschrift einzulegen.¹

Objection to this document may be filed within one month after notification. The objection must be filed in writing to, or put on record at, Federal Maritime and Hydrographic Agency, Bernhard-Nocht-Str. 78, 20359 Hamburg, Germany.

Anlage(n) Baumusterprüfbescheinigung Nr. **MCA1600002, MCA1600003**
Gebührenbescheid 790056064143

Attachment(s) *Type examination certificate no. MCA1600002, MCA1600003*
Invoice 790056064143

Mit freundlichen Grüßen

Im Auftrag

Doreen Thoma

¹ Der deutsche Text ist verbindlich.
The german text is authentic.

25014 CASTENEDOLO Brescia (ITALY) - Via Mameli, 10 - Tel. +39 030 2134.1 - Fax +39 030 2134.300
 E-mail: marco@marco.it - http://www.marco.it



DICHIARAZIONE DI CONFORMITA' DECLARATION OF CONFORMITY

Confermiamo che il prodotto
We confirm that the product

150 004 12	PW2-2BC	12V
150 004 13	PW2-2BC	24V

2 Fischi ad aria "Blitz" cromati ø200
 2 Pneumatic Whistle "Blitz" chromed ø200

È conforme alle norme RINA per l'Omologazione di Tipo secondo quanto prescritto dalla Colreg 1972, Allegato III e dal DECRETO 5 settembre 1990, n.421 concernente la sistemazione dei fanali e le caratteristiche degli apparecchi di segnalazione sonora sulle unità da diporto di **lunghezza ≤ 50 metri**.

*Is in conformity with the RINA Type Approval as per the Colreg 1972, Annex III and meets the Italian DL n.421 of the 5th of September 1990, concerning the installation of lights and the features of the sound signal devices on pleasure boats **with length ≤ 50 meters**.*



NOTE / NOTES

Lined writing area with horizontal dashed lines.



Questo documento e' proprieta' di Marco S.p.A la riproduzione e l'uso sono vietati.
Tutti i diritti sono riservati.

Per ulteriori informazioni vedere nostro sito internet - www.marco.it
Marco S.p.A Via Mameli 10 - 25014 Castenedolo (Brescia) – Italia
tel. +39 030 2134.1 / Fax +39 030 2134.300

Property of MARCO S.p.A reproduction prohibited. All rights reserved.
For further information visit our web site - www.marco.it
Marco S.p.A Via Mameli 10 - 25014 Castenedolo (Brescia) – Italy
tel. +39 030 2134.1 / Fax +39 030 2134.300