

Tank_serbatoio = 5L

Centralina idraulica 3 funzioni standard PI374 Hydraulic power pack 3 functions standard PI374

Dimensioni-ingombri massimi - Max dimension:

a = 48 Cm

b = 30 Cm

h = 34 Cm

Caratteristica motori- Engine Features:

Alimentazione - Power supply: 24 Vdc

Potenza - Power: 500 W

Pompa - Pump: 0,75Cc

Portata - Flow = 1,5 L/min

Pressioni di esercizio e assorbimenti amperometrici a motore
Max operating pressure and Amper absorption for each motor:

Pressione - Pressure: **160 Bar** Assorbimento-Absorption: **45 Amp**

Olio idraulico OSO viscosità 46 - Hydraulic oil OSO viscosity 46

Hydraulic layout configuration

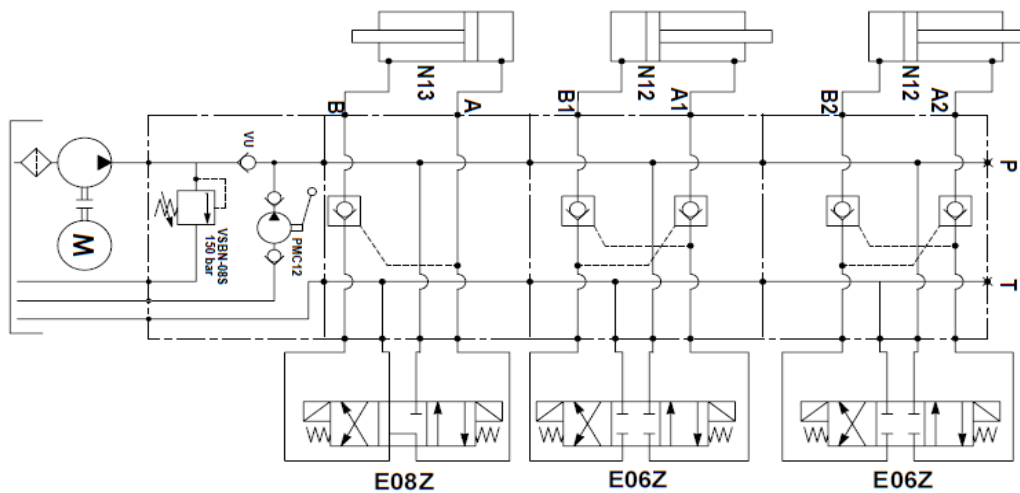

Electrical box dimensions RSP

