



Boiler System to Mixer Tap

£893.81

Excl. Tax: £744.84

Product Images

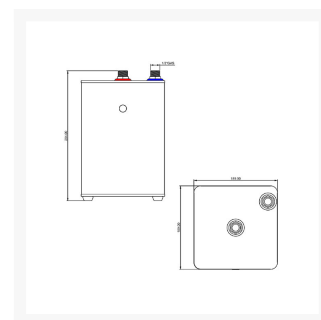

Short Description

A 2.4L stainless steel boiler system for our [Boiler Taps](#). A 110V AC – 220V AC system which provides superb convenience to your galley or deck bar area.

The tank is recharged in 2-3 minutes by a 1,5 KW non-contact element and is easily installed with simple connectors.

Description

2.4L Stainless Steel Tank

98° water supplied from the tank, with a reheating time of 2-3 minutes.

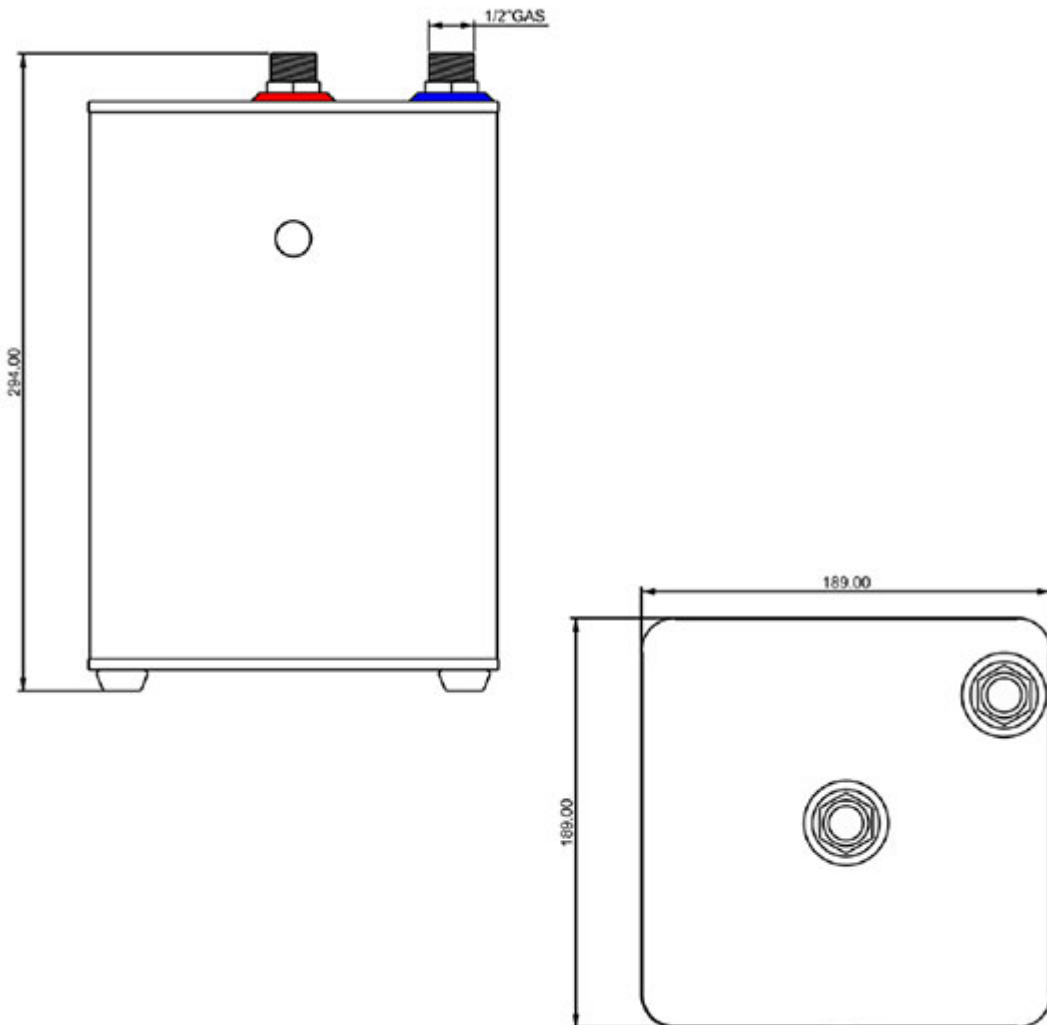

Instant Hot Water

The dedicated lever is turned for instant hot water and held for 90 seconds to fill the tank.

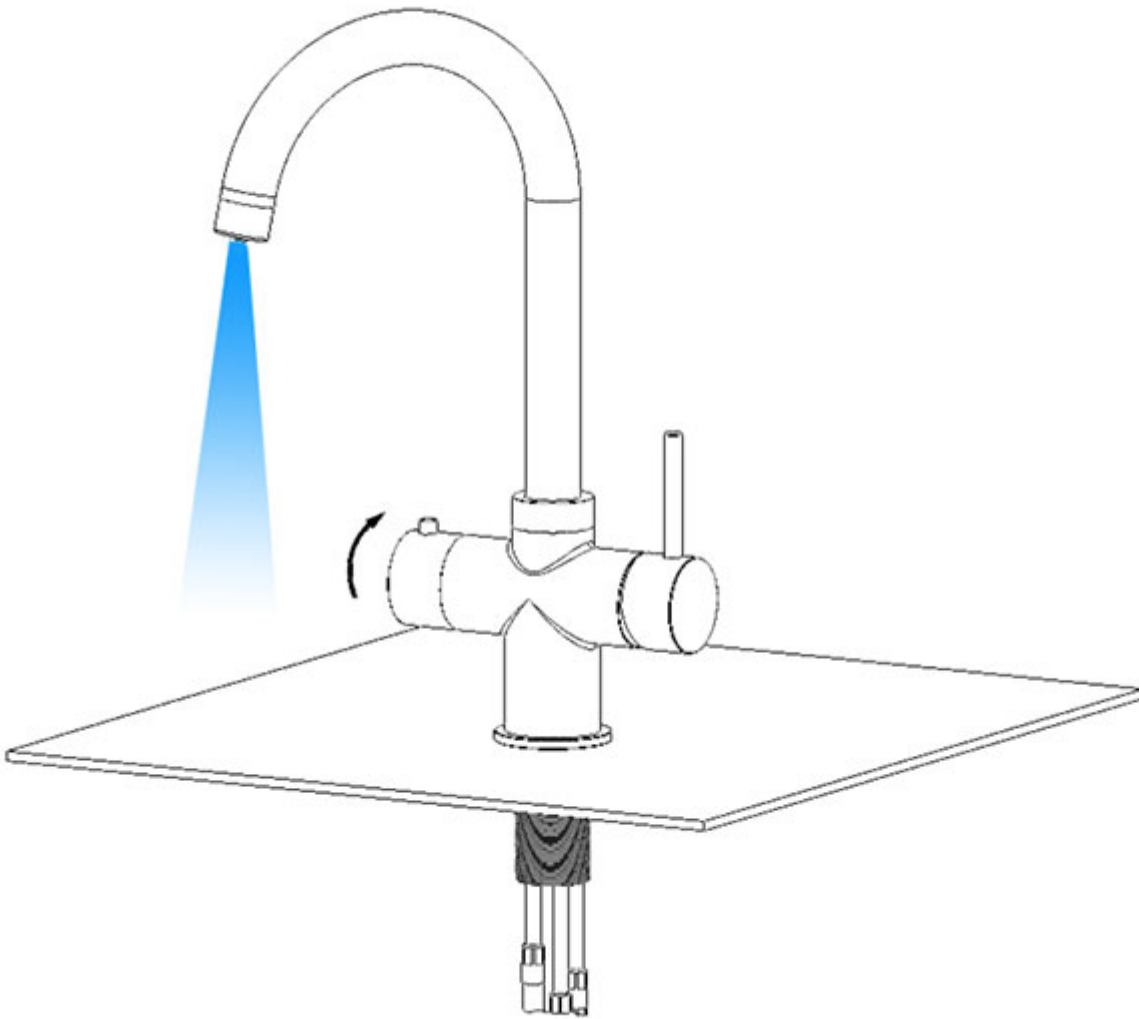

Simple Installation

The tap is fitted to the worksurface, the tank is nearby with simple connectors and a replacement filter.

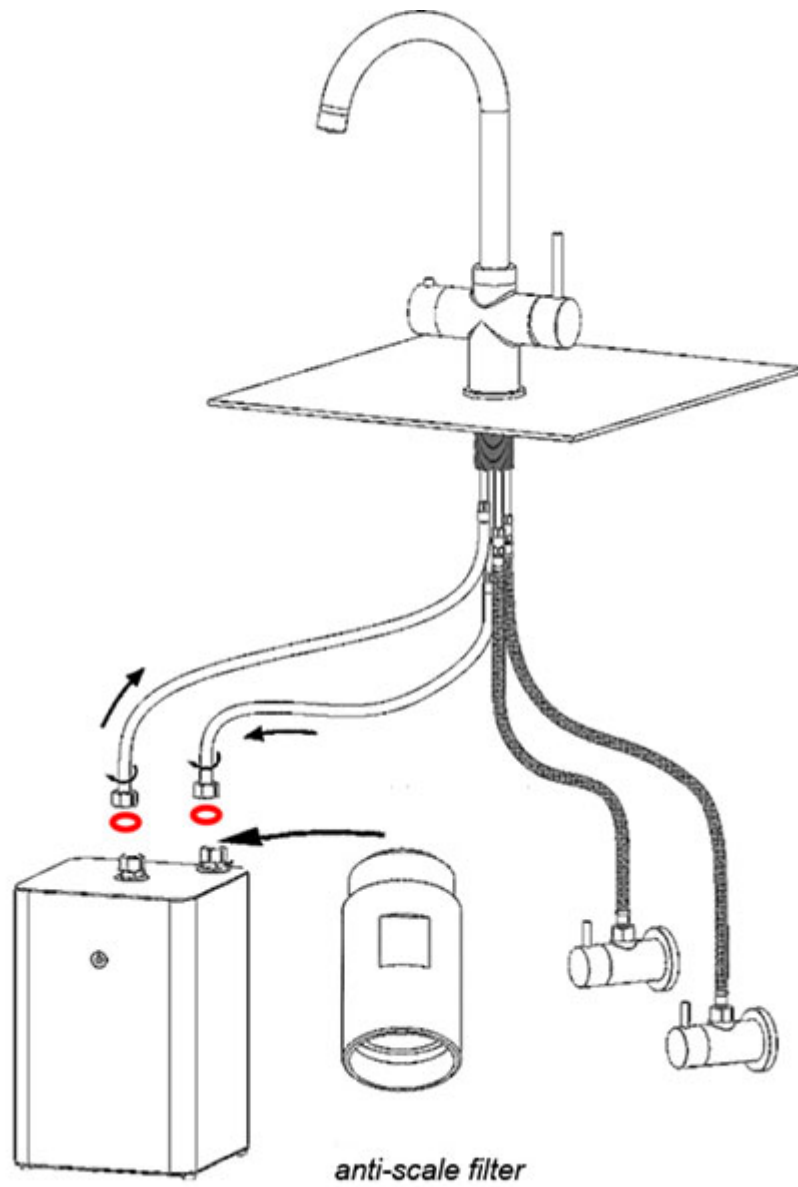

Additional Information

Input Voltage	110-220Vac
Wall Mounted	No
Weight (kg)	5.000000

